

# MEK.A.NIK.A.

WORKTABLE

---

MOUNTING GUIDE

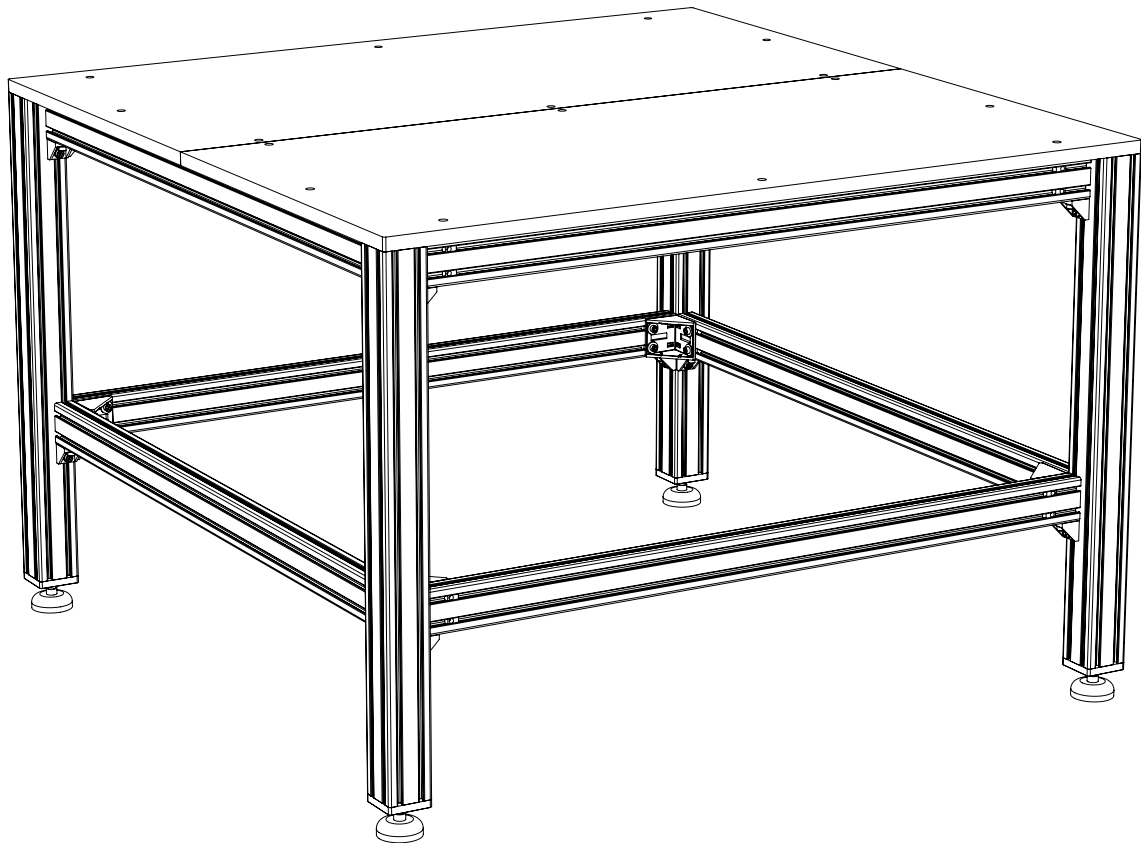







# MOUNTING GUIDE

WORKTABLE

## STEP #01

Prepare all the aluminium profile I-type 3060 (**x8**) as shown

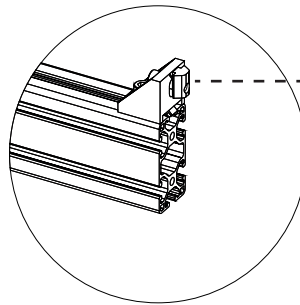
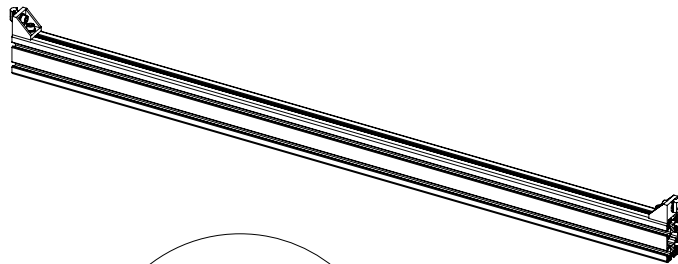

ITEM	TYPE	S	M	L
	980 mm	8	4	-
	1380 mm	-	4	8
	M6x18		32	
	M6x16		32	
	M6		32	
	I-30		16	



Pre-assemble the I-type nut with the screw and washer on the open side as well.

## STEP #02

Prepare one frame as shown by sliding the aluminium profiles 3060 (prepared at step#01) in the slot of the 6060.

ITEM	TYPE	S	M	L
	700		2	
	980 STEP#01	2	2	1
	1380 STEP#01	1	1	2

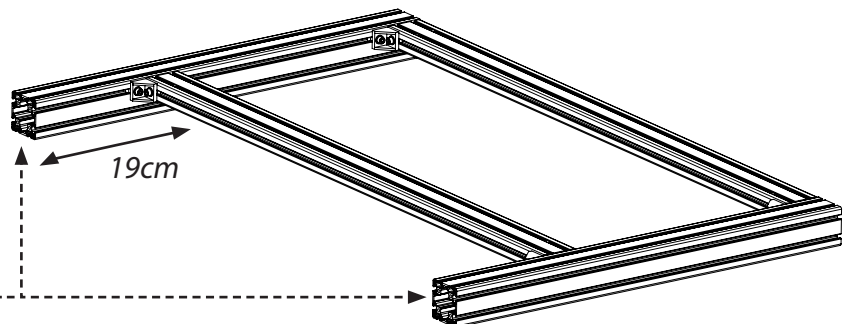



Be sure that you oriented the profiles with their threads on this side

# MOUNTING GUIDE

WORKTABLE

## STEP #03

Slide vertically the aluminium profiles 3060 (prepared at step#01) in the slot of the aluminium profiles 6060.

ITEM	TYPE	S	M	L
	980 STEP#01	4	1	1
	1380 STEP#01	1	2	2

Be sure to place the aluminium profile 3060 on the inner slot of the 6060

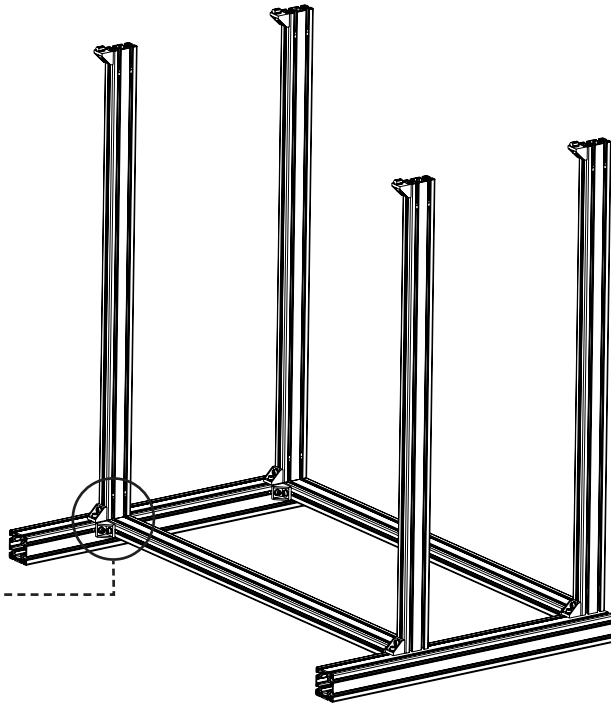
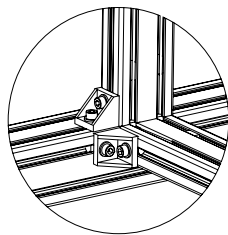

## STEP #04

Slide the two last aluminium profiles 6060 as shown.

ITEM	TYPE	S	M	L
	700 mm		2	

Be sure that you oriented the profiles with their threads on this side

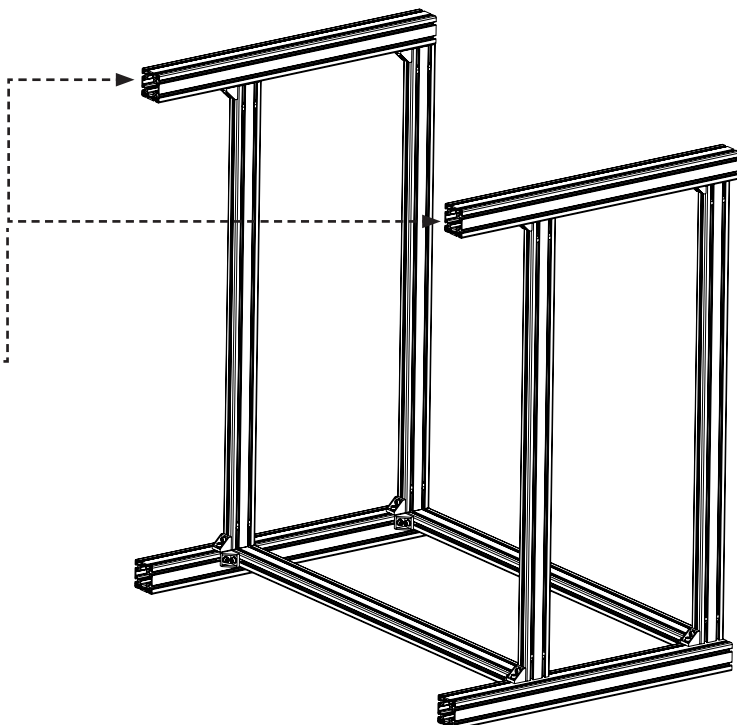



# MOUNTING GUIDE

WORKTABLE

## STEP #05

Slide the two last aluminium profile 3060 (prepared at step#01) as shown.



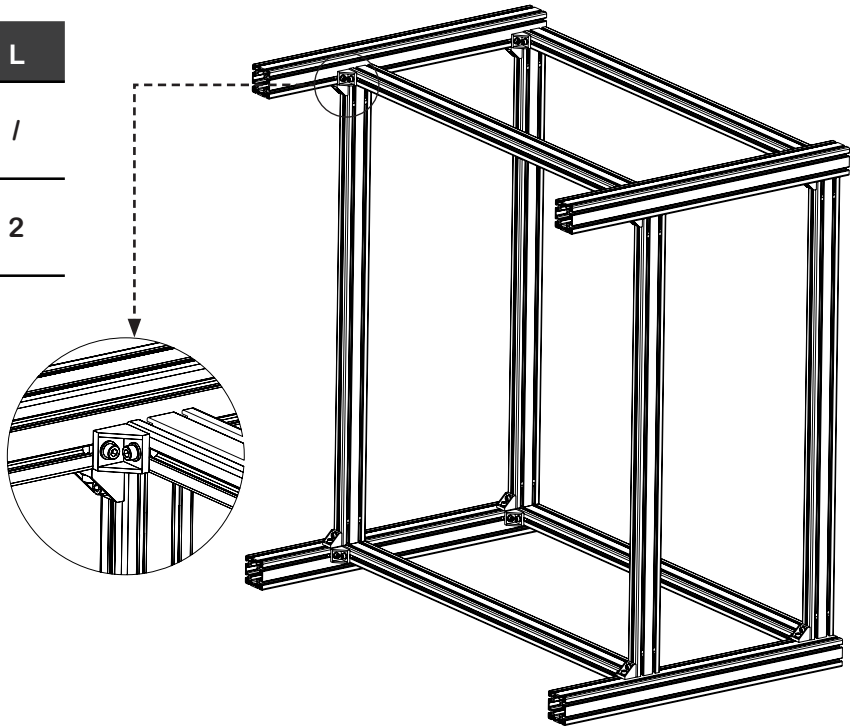

ITEM	TYPE	S	M	L
	980 STEP#01	2	2	1
	1380 STEP#01	1	1	2

Be sure to place the aluminium profile 3060 on the inner slot of the 6060



## STEP #06

Flip the table as shown and place the 8 bracket B-type 60 at every inner corners

ITEM	TYPE	S	M	L
	M6x18		32	
	M6x16		32	
	M6		32	
	60		8	

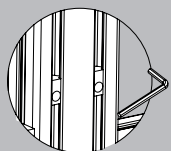
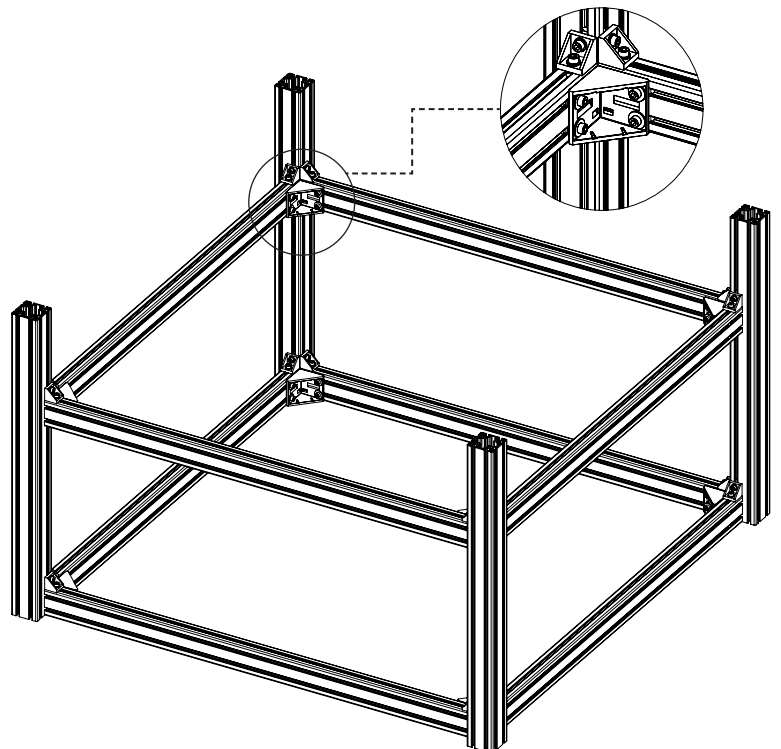







**TIPS** / To place a sliding nut when the slot is no longer accessible, use a tiny tool such as a small hex key to place it correctly

# MOUNTING GUIDE

WORKTABLE

## STEP #07

Place the last aluminium profile 3060 as shown

ITEM	TYPE	S	M	L
	980	1	1	1
	1380	1	1	1
	M6x16	8	8	16
	M6x18	8	8	16
	M6	8	8	16
	30	4	4	1
	60	1	1	4

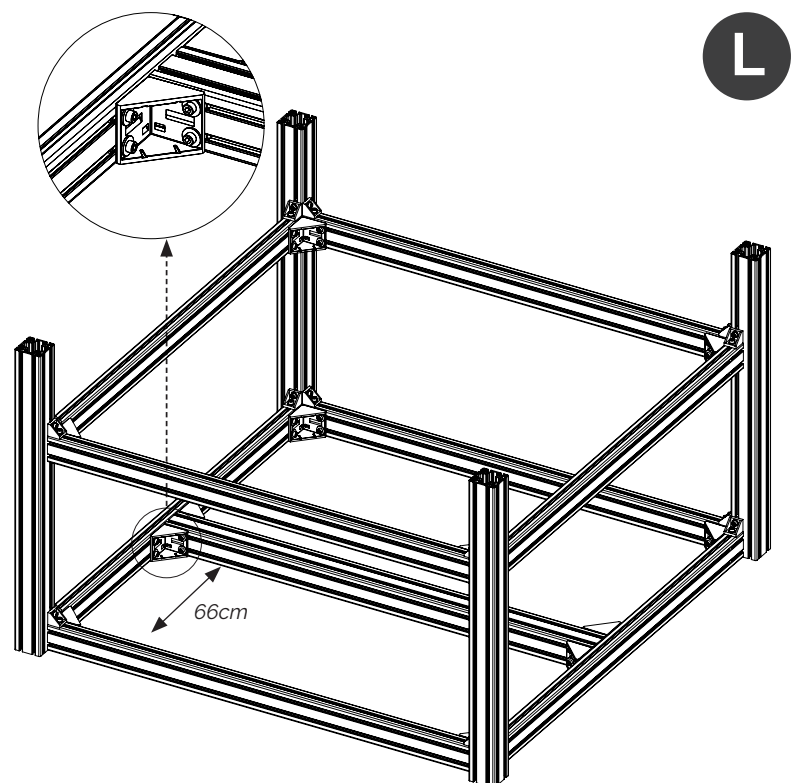
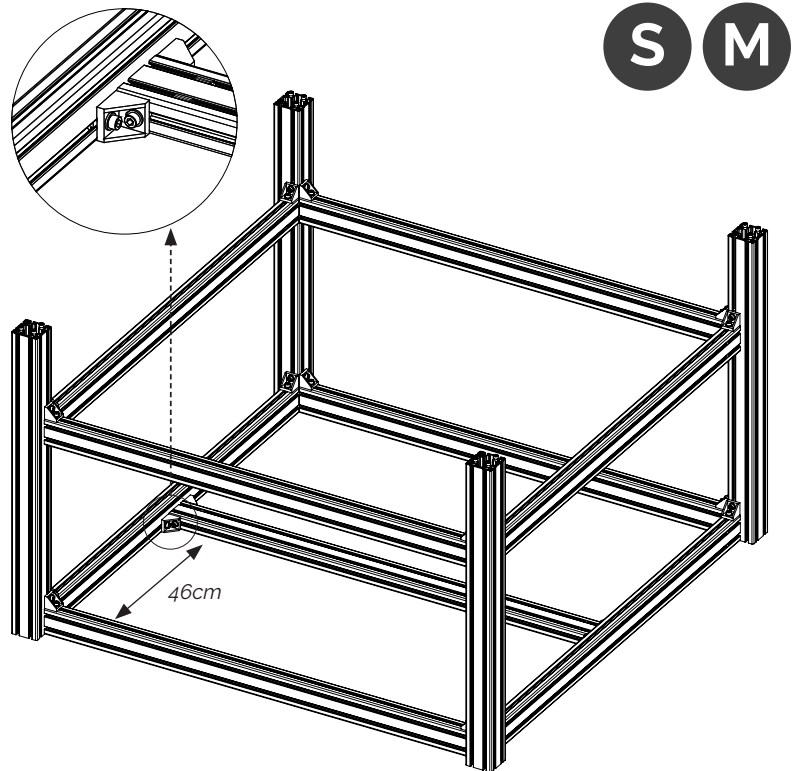





# MOUNTING GUIDE

WORKTABLE

## STEP #08

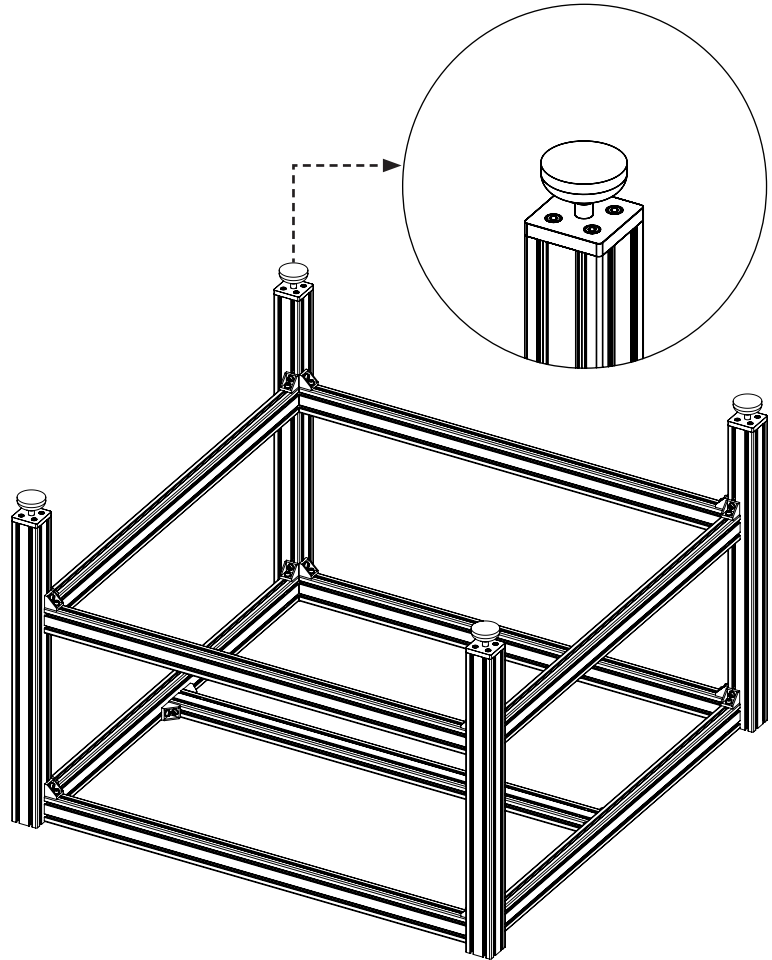

Install the foot bracket on the four table feet and screw the M12x60 plastic feet with its jam nut.

ITEM	TYPE	S	M	L
	M12x60		4	
	M6x16		16	
	M12		4	
	M12		4	



## STEP #09

Flip the table and install precisely all the sliding in order to screw the two MDF surfaces. You can adjust the level of the table by screwing or unscrewing each foot.

ITEM	TYPE	S	M	L
	18 mm		2	
	M6x20		16	
	M6		16	

